

LA CREU

VENTILACIÓN 2011

CEILING FANS 2011



 LED S-C4



Bagur.....6



Bahia..... 14



Banus8



Belmont 18



Boracay..... 22



Borneo 28



Dominica..... 24



Formentera 10



Hawaii 20



Juncal.....4



Mogan..... 16



Phuket..... 26



Toronto 12



Accesorio / Accessory...30

VENTILADORES - CEILING FANS - VENTILATEURS DE PLAFOND

Las ventajas de los ventiladores de techo La Creu:

Una temperatura óptima

Ahorro energético

En Verano:

Los ventiladores giran proporcionando una suave brisa que activa la circulación del aire impidiendo la acumulación de calor en la habitación.

En el caso de que exista una instalación del aire acondicionado, los ventiladores hacen circular el aire fresco de forma uniforme, evitando que el aparato de aire acondicionado esté en uso de forma constante pudiendo ahorrar energía hasta un 40% y reduciendo la factura de electricidad.

En Invierno:

También en Invierno los ventiladores La Creu son útiles. El aire caliente pesa menos que el aire frío, por lo que tiende a concentrarse en el techo. Los ventiladores La Creu giran inversamente a como lo hacen en verano, haciendo que el aire acumulado en el techo baje y el calor se distribuya por toda la habitación.

Escoja el mejor ventilador para cada habitación:

- Habitaciones de hasta 15 m² – Se aconseja un diámetro de ventilador de menos de 112 cm.
- Habitaciones de hasta 25 m² – Se aconseja un diámetro de ventilador de 112 cm a 122 cm.
- Habitaciones de hasta 40 m² – Se aconseja un diámetro de ventilador de 132 cm a 137 cm.

Situación del ventilador:

- La distancia máxima hasta el suelo: 2,3 m. Si existe más distancia el aire no llegará bien.
- La distancia mínima desde el extremo exterior de la pala hasta la pared: 0,6 m.

The advantages of La Creu ceiling fans:

An optimum temperature

Energy savings

In Summer:

The fans rotate and give off a soft breeze that activates air circulation, thus preventing an accumulation of heat in the room.

In the event that there is an air conditioning unit, the fans circulate fresh air evenly. They thus prevent the air conditioning unit from being constantly in use.

As a result, there can be an energy savings of up to 40% which lowers the electricity bill.

In Winter:

La Creu fans are also useful in Winter. Hot air weighs less than cold air. Therefore, it tends to concentrate near the ceiling. La Creu fans rotate inversely to the direction in which they rotate in summer, they make the air accumulated near the ceiling descend. Then heat is distributed throughout the room.

Choose the best fan for each room:

- Rooms up to 25 m² - We recommend a fan with a diameter of less than 112 cm.
- Rooms up to 25 m² - We recommend a fan with a diameter from 112 cm to 122 cm.
- Rooms up to 40 m² - We recommend a fan with a diameter from 132 cm to 137 cm.

Fan location:

- The maximum distance to the floor is 2.3 m. If the distance is greater, the air will not properly reach its target.
- The minimum distance from the blade's outer edge to the wall: 0.6 m.

Les avantages des ventilateurs de plafond La Creu :

Une température optimale

Économie d'énergie

En été :

Les ventilateurs tournent en apportant une douce brise qui active la circulation de l'air et empêche l'accumulation de chaleur dans la pièce.

Dans le cas où il existe une installation de climatisation, les ventilateurs font circuler uniformément l'air frais en évitant que l'appareil soit en utilisation continue, ce qui permet une économie d'énergie allant jusqu'à 40 % et une réduction de la facture d'électricité.

En hiver :

Les ventilateurs La Creu sont aussi utiles en hiver. L'air chaud est moins lourd que l'air froid, donc il tend à se concentrer au plafond. Les ventilateurs La Creu tournent en sens inverse de celui suivi en été en permettant que l'air accumulé au plafond descende et que la chaleur se distribue dans toute la pièce.

Choisissez votre ventilateur en fonction de la surface de la pièce à ventiler :

- Pièces allant jusqu'à 15 m² - On conseille un diamètre du ventilateur de moins de 112 cm.
- Pièces allant jusqu'à 25 m² - On conseille un diamètre du ventilateur de 112 à 122 cm.
- Pièces allant jusqu'à 40 m² - On conseille un diamètre du ventilateur de 132 à 137 cm.

Emplacement du ventilateur :

- Distance maximale jusqu'au sol: 2,3 m. Si la distance est supérieure, l'air n'arrivera pas correctement.
- Distance minimale de l'extrémité extérieure de la pale au mur: 0,6 m.

DECKENVENTILATOREN - VENTILATORI DA SOFFITTO - VENTILADORES DE TECTO

Die Vorteile der Deckenventilatoren La Creu:

Eine optimale Raumtemperatur

Energiesparend

Im Sommer:

Durch die Ventilatorumdrehung wird sanfter Wind erzeugt, die Umwälzung der Luft im Raum gefördert und das Anstauen der Wärme in einzelnen Bereichen des Zimmers verhindert. Bei gleichzeitigem Betrieb einer Klimaanlage bewirken Ventilatoren ein gleichmäßiges Zirkulieren der kühlen Luft. Auf diese Weise muss das Klimagerät nicht ständig auf Hochtouren laufen und es können bis zu 40% des Energieverbrauchs eingespart werden, was eine dementsprechende Senkung der Stromrechnung zur Folge hat.

Im Winter:

Auch im Winter sind die Ventilatoren La Creu nützlich. Warmluft weist ein geringeres Gewicht als Kaltluft auf, weshalb sie dazu neigt, sich unterhalb der Zimmerdecke anzustauen. Die Ventilatoren La Creu laufen dann in umgekehrter Drehrichtung als im Sommer, dadurch sinkt die an der Decke angestaute Luft nach unten und die Wärme verteilt sich gleichmäßig im gesamten Raum.

Wählen Sie den geeignetsten Ventilator für jedes Zimmer:

- Zimmer bis zum 15 m² - Empfohlen werden Ventilatoren mit einem Durchmesser kleiner als 112 cm.
- Zimmer bis zum 25 m² - Empfohlen werden Ventilatoren mit einem Durchmesser von 112 cm bis 122 cm.
- Zimmer bis zum 40 m² - Empfohlen werden Ventilatoren mit einem Durchmesser von 132 cm bis 137 cm.

Montageabstände vom Ventilator:

- Der Höchstabstand zum Boden beträgt: 2,3 m. Bei höheren Abständen kann der Luftzug nur unzureichend verspürt werden.
- Der Mindestabstand von der oberen Kante der Flügelplatte zur Wand beträgt 0,6 m.

I vantaggi dei ventilatori da soffitto La Creu:

Temperatura ottimale

Risparmio energetico

In estate:

I ventilatori girano emettendo una leggera brezza che attiva la circolazione dell'aria, impedendo l'accumulo di calore nell'abitazione. Qualora sia presente un impianto di condizionamento dell'aria, i ventilatori faranno circolare l'aria fresca in modo uniforme, evitando il funzionamento continuo del condizionatore dell'aria e consentendo quindi un risparmio energetico fino al 40%, con conseguente riduzione dei costi per l'energia elettrica.

In inverno:

I ventilatori La Creu sono utili anche in inverno. L'aria calda ha un peso inferiore rispetto all'aria fredda, poiché tende a concentrarsi sul soffitto. I ventilatori La Creu girano in senso opposto rispetto a quello effettuato in estate, consentendo la discesa dell'aria accumulata sul soffitto e garantendo quindi una distribuzione del calore in tutta l'abitazione.

Selezione del ventilatore più appropriato per ogni stanza:

- Stanze fino a 15 m² - si consiglia un ventilatore con diametro inferiore a 112 cm.
- Stanze fino a 25 m² - si consiglia un ventilatore con diametro da 112 cm a 122 cm.
- Stanze fino a 40 m² - si consiglia un ventilatore con diametro da 132 cm a 137 cm.

Ubicazione del ventilatore:

- Distanza massima dal pavimento: 2,3 m. Una distanza maggiore non consentirà una corretta propagazione dell'aria.
- Distanza minima dell'estremità esterna della pala dalla parete: 0,6 m.

As vantagens dos ventiladores de tecto La Creu:

Uma temperatura ótima

Poupança de energia

No Verão:

Os ventiladores giram proporcionando uma suave brisa que activa a circulação do ar, impedindo a acumulação de calor na habitação. Caso haja uma instalação de ar condicionado, os ventiladores fazem circular uniformemente o ar fresco, evitando que o aparelho de ar condicionado esteja constantemente em uso, podendo poupar até 40% de energia e reduzindo a factura da electricidade.

No Inverno:

No Inverno os ventiladores La Creu também são úteis. O ar quente pesa menos do que o ar frio, pelo que tende a concentrar-se no tecto. Os ventiladores La Creu giram inversamente à forma como o fazem no Verão, fazendo com que o ar acumulado no tecto baixe e o calor se distribua por toda a habitação.

Escolha o melhor ventilador para cada quarto:

- Compartimentos até 15 m² - Aconselha-se um diâmetro de ventilador de 112 cm.
- Compartimentos até 25 m² - Aconselha-se um diâmetro de ventilador de 112 cm a 122 cm.
- Compartimentos até 40 m² - Aconselha-se um diâmetro de ventilador de 132 cm a 137 cm.

Localização do ventilador:

- A distância máxima até ao solo é de 2,3 m. Se houver uma maior distância, o ar não chegará bem.
- A distância mínima desde a extremidade exterior da pá até à parede é de 0,6 m.

Juncal

DESIGN:
Stimulo

N3
Gris textura
Grey texture
Gris à effet de texture
Grau matt
Grigio
Cinzeno textura

M1
Difusor acrílico
Acrylic diffuser
Diffuseur acrylique
Acryl-Diffusor
Diffusore acrilico
Difusor acrilico

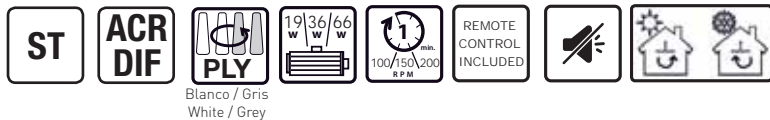

Mando a distancia - incluido
Remote control - included



30-4392-N3-M1

1 x 2GX13 Max.55W

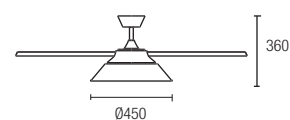
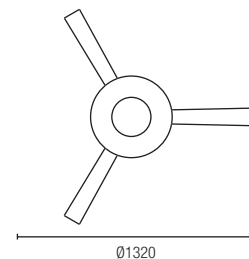



Bagur

DESIGN:
Estudi Ribaudí

14
Blanco
White
Blanc
Weiss
Bianco
Branco

F9
Cristal opal mate
Matt opal glass
Verre opalin mate
Matt opales Glas
Vetro ottico satinato
Vidro opalino mate

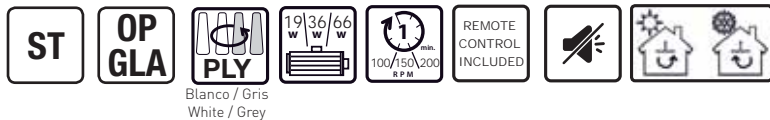

Mando a distancia - incluido
Remote control - included



30-4394-14-F9

2 x E-27 Max. 40W

2 x PL Elec E-27 Max. 15W

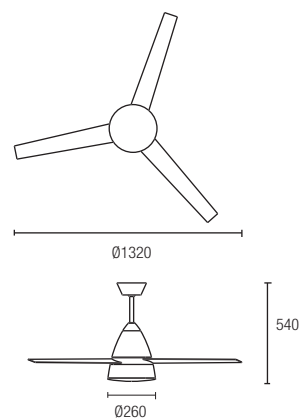



Banus

DESIGN:
Fransesc Vilaró

J7
Marrón cobrizo
Copper brown
Marron cuivré
Kupferrot braun
Marrón color rame
Marrom acobreado

M1
Difusor acrílico
Acrylic diffuser
Diffuseur acrylique
Acryl-Diffusor
Diffusore acrilico
Difusor acrilico



Wengué / Blanco
Wenge / White



Mando a distancia - incluido
Remote control - included



30-4395-J7-M1

2 x PL Elec E-27 Max. 23W

Recommended Twist Osram

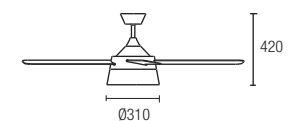
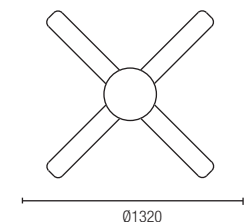



Formentera

DESIGN:
Estudi Ribaudí

N3
Gris textura
Grey texture
Gris à effet de texture
Grau matt
Grigio
Cinzeno textura

M1
Difusor acrílico
Acrylic diffuser
Diffuseur acrylique
Acryl-Diffusor
Diffusore acrilico
Difusor acrilico



Blanco / Gris
White / Grey



Mando a distancia - incluido
Remote control - included



30-4393-N3-M1

1 x PL Elec E-27 Max.23W

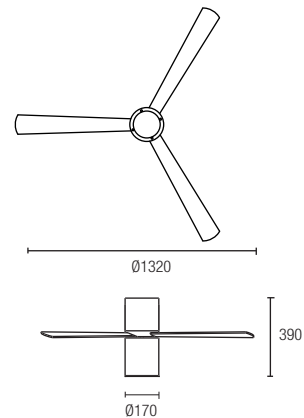



Toronto

DESIGN:
Benedito Design

81
Níquel satinado
Satin nickel
Nickel satiné
Nickel matt
Nichel satinado
Níquel acetinado

M1
Difusor acrílico
Acrylic difusser
Diffuseur acrylique
Acryl-Diffusor
Diffusore acrilico
Difusor acrilico

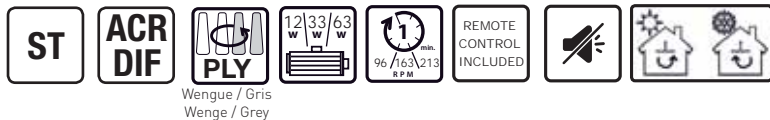

Wengue / Gris
Wenge / Grey



Mando a distancia - incluido
Remote control - included



30-4354-81-M1

1 x 2GX13 55W 

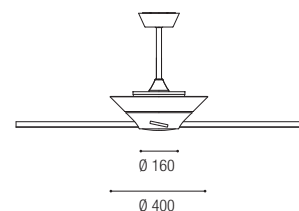
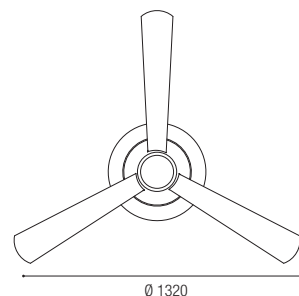



Bahia

DESIGN:
Benedito Design

81
Níquel satinado
Satin nickel
Nickel satiné
Nickel matt
Nichel satinado
Níquel acetinado

14
Blanco
White
Blanc
Weiss
Bianco
Branco

M1
Difusor acrílico
Acrylic diffuser
Diffuseur acrylique
Acryl-Diffusor
Diffusore acrilico
Difusor acrilico



Mando a distancia - incluido
Remote control - included



30-4355-81-M1

1 x 2GX13 55W

Wengue / Gris
Wenge / Grey

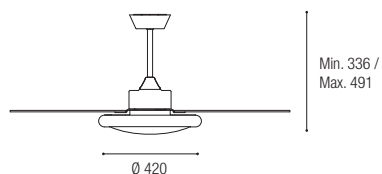
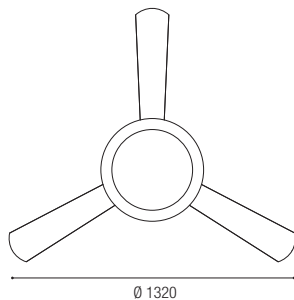

30-4355-14-M1

1 x 2GX13 55W

Blanco / Gris
White / Grey





Mogan

DESIGN:
Yago Sarri

Blanco
White
Blanc
Weiss
Bianco
Branco

14



Blanco / Blanco
White / White



Mando a distancia - incluido
Remote control - included



30-4356-14-14

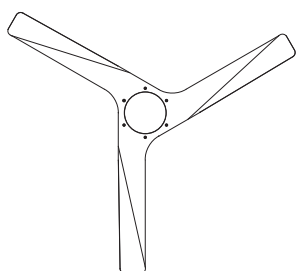

Ø 1320



Min. 305 /
Max. 460





Belmont

DESIGN:
Yago Sarri

81
 Níquel satinado
 Satin nickel
 Nickel satiné
 Nickel matt
 Níquel satinado
 Níquel acetinado

20
 Pantalla tela beige
 Beige fabric shade
 Abat-jour en toile beige
 Stoffschirm beige
 Schermo in tela beige
 Abat-jour de tecido beige

AJ
 Pantalla gris ópera
 Opera grey shaded
 Abat-jour gris opéra
 Grauer Schirm
 Paralumè grigio opera
 Abat-jour cinzento opéra



Wengue / Gris
 Wenge / Grey



Mando a distancia - incluido
 Remote control - included



Para conjunto completo solicite referencias de ventilador y pantalla
 For complete set please order by separate ceiling fan and shade reference

30-4357-81-82

3 x PL Elec. E27 Max. 18W

3 x E-27 Max. 60W

PAN 146-20

PAN 146-AJ

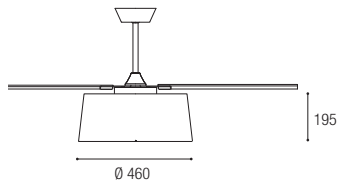
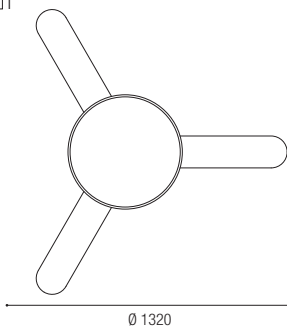

Min. 488 /
 Max. 543





Hawaii

81
 Níquel satinado
 Satin nickel
 Nickel satiné
 Nickel matt
 Níquel satinado
 Níquel acetinado

F9
 Cristal opal mate
 Matt opal glass
 Verre opalin mate
 Matt opales Glas
 Vetro ottico satinato
 Vidro opalino mate



Wengue / Gris
 Wenge / Grey



Mando a distancia - incluido
 Remote control - included



30-2854-81-F9

1 x R7s Max. 100W OSRAM included

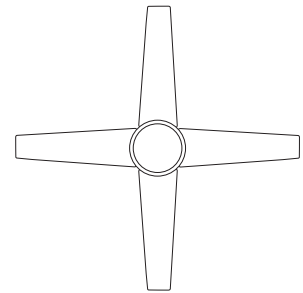

Ø 1322

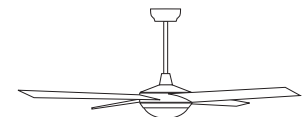

Min. 360 /
 Max. 515



Boracay

Mando a distancia - opcional
Remote control - optional

71-4399-14-14

<p>14</p> <p>Blanco White Blanc Weiss Bianco Branco</p>	<p>81</p> <p>Níquel satinado Satin nickel Nickel satiné Nickel matt Nichel satinado Nichel acetinado</p>	<p>F9</p> <p>Cristal opal mate Matt opal glass Verre opalin mate Matt opales Glas Vetro ottico satinato Vidro opalino mate</p>
---	--	--



30-4404-14-F9

1 X PL Elec G9 Max. 9W

1 x G9 Max. 60W

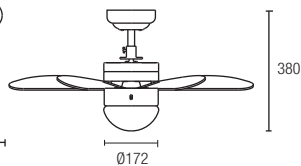
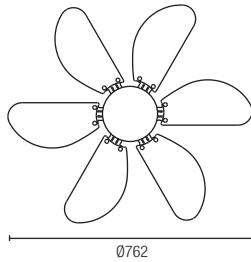

30-4404-81-F9

1 X PL Elec G9 Max. 9W

1 x G9 Max. 60W





Dominica

Mando a distancia - opcional
Remote control - optional

71-4399-14-14

J7
Marrón cobrizo
Copper brown
Marron cuivré
Kupferrot braun
Marrón color rame
Marrom acobreado

E7
Cristal decorado
Decorated glass
Verre décoré
Dekoriertes Glas
Cristallo decorato
Vidrio decorado



Wengué / Teka
Wenge / Teka



30-4405-J7-E7

3 x E-27 Max.60W

3 x PL Elec. E-27 Max.15W

Recommended Mini ball 3 x 15W

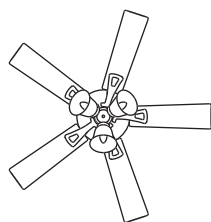

Ø1066

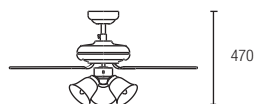



Phuket

Mando a distancia - opcional
Remote control - optional

71-4399-14-14

<p>J7</p> <p>Marrón cobrizo Copper brown Marron cuivré Kupferrot braun Marrón color rame Marrom acobreado</p>	<p>F9</p> <p>Cristal opal mate Matt opal glass Verre opalin mate Matt opales Glas Vetro ottico satinato Vidro opalino mate</p>
--	---

⊕ ⊖ CE ENERGY SAVING IP 23

ST	OPA GLA	ABS	14/28/56 w/w/w	1 min. 80 / 120 / 175 R.P.M.			
-----------	----------------	------------	-------------------	------------------------------------	--	--	--

Marrón cobrizo /
Copper brown

71-4398-J7-F9

2 x PL Elec. E-27 Max. 18W

2 x E-27 Max. 60W

Kit de luces opcional / Optional lighting kit

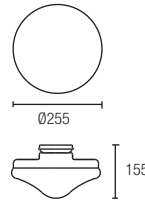

Adecuado para exterior / Suitable for outdoor

30-4398-J7-J7

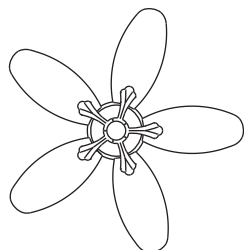



Ø1320



Simil Ratán / Similar to Rattan



Borneo

 Marrón cobrizo Copper brown Marron cuivré Kupferrot braun Marróne color rame Marrom acobreado	 Níquel satinado Satin nickel Nickel satiné Nickel matt Níchel satinado Níquel acetinado	 Cristal opal mate Matt opal glass Verre opalin mate Matt opales Glas Vetro ottico satinato Vidro opalino mate
J7	81	F9



Mando a distancia - incluido
Remote control - included



30-4399-81-F9

2 x PL Elec. E-27 Max.13W 

2 x E-27 Max.60W 

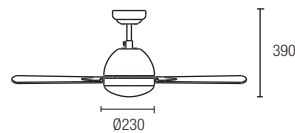
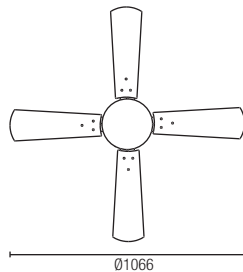

30-4399-J7-F9

2 x PL Elec. E-27 Max.13W 

2 x E-27 Max.60W 























71-4399-14-14

Mando a distancia
Remote control
Télécommandes
Fernbedienung
Comando a distanza
Control remoto

Simbología • Symbols • Symboles • Symbole • Simbologia • Simbologia

-  Clase I • Class I • Classe I • Classe I • Classe I • Classe I
-  Instalable sobre una superficie normalmente inflamable • Suitable for installation on normally inflammable surfaces • Installation sur une surface normalement inflammable • Darf unter normalen Bedingungen auf leicht entzündbaren Oberflächen angebracht werden • Tutte le lampade contraddistinte con questo simbolo sono costruite in modo tale da poter essere installate su di una superficie normalmente infiammabile • Instalável sobre uma superfície normalmente inflamável
-  Modelos registrados • Registered models • Modèles enregistrés • Eingetragene Modelle • Modelli registrati • Modelos registrados
-  Fabricado según normas de seguridad y electromagnetismo de Europa • Manufactured according to the set safety and electromagnetism standards of Europe • Fabriqués en conformité avec les normes de sécurité et d'électromagnétique de l'Europe • Europa geltenden Sicherheitsbestimmungen • Tutti i prodotti fabbricati rispettano le norme di sicurezza e di elettromagnetismo europee • Fabricado de acordo com as normas de segurança e electromagnetismo da Europa
-  Uds. de embalaje • Items per box • Unité d'emballage • Verpackungseinheiten • Unità per scatola • Uds. por embalagem
-  Dirección del halo de luz • Halo light direction • Direction du faisceau lumineux • Lichtstrom in Richtung • Direzione del fascio luminoso • Direcção do feixe de luz.
-  Bajo consumo • Energy saving • Économie d'énergie • Energiesparlampe • Risparmio energetico • Poupança de energia

IP 23 Lámpara protegida contra la penetración de objetos sólidos mayores de 12mm y contra el agua en forma de lluvia hasta 60° de inclinación • Lamp protected against ingress of solid objects greater than 12mm and against spraying water • Luminaire protégée contre la pénétration d'objets solides d'une taille supérieure à 12mm, et contre l'eau de pluie inclinée à plus de 60° • Lampe geschützt gegen das Eindringen von festen Gegenständen, die größer als 12 mm sind und gegen Regenwasser mit einer Inklination bis zu 60° • Lampada protetta dalla penetrazione di oggetti solidi più grandi di 12 mm e dall'acqua a forma di pioggia fino a 60° di inclinazione • Luminária protegida contra a penetração de objectos sólidos >12mm e contra a penetração de água em forma de chuva até uma inclinação de 60°.

-  Palas reversibles • Reversible blades • Lames réversibles • Zweifarbige umkehrbare Blätter • Lame reversibili • Lâminas revogáveis
-  Revoluciones por minuto • Revolutions per minute • Révolutions par minute • Umdrehungen pro Minute • Evoluzioni al minuto • Rotações por minuto
-  3 Velocidades • 3 Speeds • 3 Vitesses • 3 Geschwindigkeiten • 3 velocità • 3 velocidades
-  Silencioso • Quiet • Silencieux • Ruhig • Silenzioso • Silencioso
-  Control remoto incluido • Remote control included • Télécommande inclus • Fernbedienung inklusiv • Comando a distanza incluso • Control remoto incluído
-  Palas de contrachapado • Plywood blades • Pale en contreplaqué • Sperrholz Blätter • Pale compensato • Pás contraplacado
-  Palas de ABS • ABS blades • Pale en ABS • ABS Blätter • Pale ABS • Pás ABS
-  Palas de acero • Steel blades • Pale en acier • Stahl Blätter • Pale acciaio • Pás aço
-  El giro a la izquierda crea un efecto refrigerante, perfecto para el verano • A rotation to the left causes a cooling effect, perfect for the summer • La rotation vers la gauche crée un effet rafraîchissant, parfait pour l'été • Die Umdrehung nach links verursacht ein Kühleffekt, ideal für den Sommer • Girare a sinistra da un effetto refrigerante, ottimo per l'estate • A rotação à esquerda cria um efeito refrescante, que é ideal para o Verão
-  El giro a la derecha envía el aire más caliente hacia abajo, ideal para el invierno • A rotation to the right sends warm air down, ideal for the winter • La rotation vers la droite envoie l'air le plus chaud vers le bas, idéal pour l'hiver • Die Umdrehung nach rechts sendet die Warmluft abwärts, ideal für den Winter • Girare a destra manda l'aria più calda in basso, ideale per l'inverno • A rotação à direita envia o ar mais quente para baixo, que é ideal para o Inverno

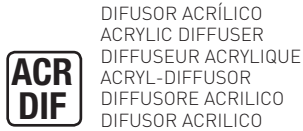
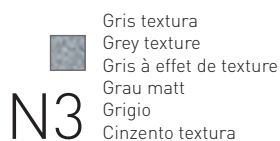
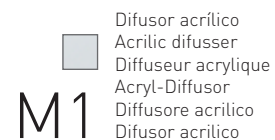
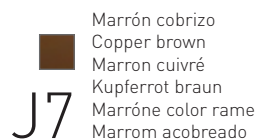
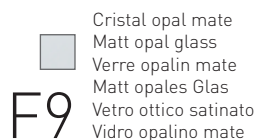
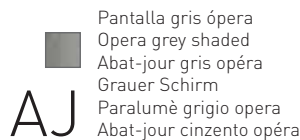
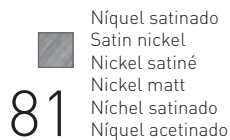
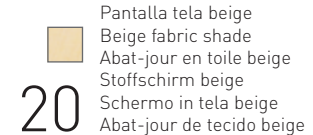
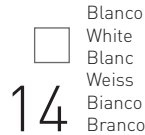
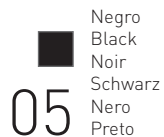
Materiales • Materials • Matériaux • Materialien • Materiali • Materiais

Acabados • Finishing • Finitions • Ausführungen • Rifiniture • Acabamentos

Índice • Index • Index • Index • Indice • Índice

30-2854-81-F9.....	20	30-4398-J7-J7	26
30-4354-81-M1	12	30-4399-81-F9.....	28
30-4355-14-M1	14	30-4399-J7-F9.....	28
30-4355-81-M1	14	30-4404-14-F9.....	22
30-4356-14-14	16	30-4404-81-F9.....	22
30-4357-81-82.....	18	30-4405-J7-E7.....	24
30-4392-N3-M1	4	71-4398-J7-F9.....	26
30-4393-N3-M1.....	10	71-4399-14-14	30
30-4394-14-F9.....	6	PAN 146-20.....	18
30-4395-J7-M1	8	PAN 146-AJ.....	18

Información general • General information • Information générale • Allgemeine Informationen • Informazioni generale • informação geral

• Las descripciones y medidas de los aparatos del presente catálogo son orientativas, pudiendo por tanto ser modificadas, a fin de mejorar las características técnicas o de diseño. • La empresa se reserva el derecho de anular o modificar cualquier modelo sin previo aviso. • Todos los modelos presentados cumplen las normas exigidas por la C.E. para aparatos de iluminación de uso doméstico y sus características vienen determinadas por las clases I y II. • Los acabados y las especificaciones técnicas corresponden a los productos que se suministran en Europa, pudiendo éstos variar en otros mercados. • Para una buena conservación de las lámparas, no usar bombillas de potencia superior a las recomendadas y limpiar simplemente con un paño seco. No usar limpiametales, ya que dañan los barnices protectores que garantizan la duración del acabado.

• The descriptions and dimensions of the items in this catalogue are indicative and may be modified for the purpose of technical or design improvements. • We reserve the right to cancel or change all models without prior notice • All items meet the E.C. Class I and Class II safety regulations for home lighting appliances. • The finishes and technical specifications listed here are for the European market and may vary elsewhere. • Do not use stronger bulbs than recommended, and always clean lamps with a soft dry cloth alone since metal polish will damage the protective finish.

• Les descriptions et mesures des appareils de ce catalogue sont données à titre d'orientation, pouvant être modifiées dans le but d'améliorer les caractéristiques techniques ou de design. • L'usine se réserve le droit d'annuler ou modifier l'un ou l'autre de ses modèles sans avis préalable. • Tous les modèles présentés sont conformes aux normes exigées par la C.E. pour les appareils d'éclairage domestique et leur caractéristiques sont déterminées par le classe I et II. • Les finitions et spécifications techniques correspondent à la demande du marché européen. Elles peuvent être modifiées pour d'autres pays. • Ne pas utiliser d'ampoules d'une puissance supérieure à celle recommandée. Pour un bon entretien, utiliser simplement un chiffon sec. N'utilisez aucun produit pour métaux, ils abîment le vernis protecteur.

• Die Beschreibung und Maße der in diesem Katalog aufgeführten Modelle dienen der Orientierung und können zur Verbesserung der technischen Eigenschaften oder des Designs geändert werden. • Der Hersteller behält sich das Recht vor, Modelle zu ändern oder aus dem Programm zu nehmen. • Die gezeigten Modelle erfüllen alle die innerhalb der EU geforderten Normen und Richtlinien für Leuchten für allgemeine Beleuchtungszwecke der Schutzklassen I und II. • Die Ausführungen und technischen Daten gelten für den europäischen Markt und können in anderen Ländern abweichen. • Für eine gute Erhaltung der Leuchten ist der Betrieb mit Lampen höherer Leistung als empfohlen zu vermeiden. Zur Reinigung benutzen Sie einfach ein trockenes Tuch, da Metallputzmittel die Schutzlackierung angreifen.

• Le descrizioni e le dimensioni degli articoli del presente catalogo vengono fornite a mero titolo indicativo e possono pertanto essere modificate al fine di migliorarne le caratteristiche tecniche o di design. • La Casa si riserva il diritto di cessare la produzione o di modificare qualsiasi modello senza preavviso. • Tutti i modelli presentati sono conformi alle normative C.E. per gli articoli di illuminazione per uso domestico di classe I e II. • Le rifiniture e le specifiche tecniche corrispondono ai prodotti venduti in Europa; tali dati possono pertanto variare su altri mercati. • Per una buona conservazione delle lampade, non utilizzare lampadine di potenza superiore a quella consigliata e pulirle semplicemente con un panno asciutto. Non utilizzare prodotti per la pulizia del metallo che potrebbero rovinare le vernici di protezione che garantiscono la vita della rifinitura.

• As descrições e medidas dos modelos do presente catálogo são orientativas podendo, portanto, ser modificadas com o fim de melhorar as características técnicas ou de desenho. • A empresa reserva-se o direito de anular ou modificar qualquer modelo sem aviso prévio. • Todos os modelos apresentados cumprem as normas CE para aparelhos de iluminação de uso doméstico e as suas características de protecção estão definidas pelas Classes I ou II. • Os acabamentos e especificações técnicas correspondem aos produtos fornecidos na Europa, podendo estes ser diferentes em outros mercados. • Para bom funcionamento e manutenção dos aparelhos, nunca usar lâmpadas de potência superior à recomendada nem usar produtos para limpeza de metais porque podem danificar os vernizes de protecção que garantem a durabilidade do acabamento. Para limpeza usar apenas um pano seco.

Todos los derechos reservados. Ninguna parte de este libro puede ser reproducida en ningún formato de papel o electrónico, sin el consentimiento previo del editor o de los propietarios de los derechos.

All rights reserved. No part of this publication may be reproduced or transmitted in any form or by any means, electronic storage and retrieval system, without permission in writing from the copyright owner (s).
Tous droits réservés. Aucune partie de ce livre ne pourra être reproduite en format papier ou électronique sans l'autorisation préalable de l'éditeur ou du propriétaire des droits.

Sämtliche Rechte vorbehalten. Kein Teil dieses Buches darf in keinem Papier-oder elektronischem Format ohne ausdrückliche Zustimmung des Herausgebers oder der Inhaber der Urheberrechte wiedergegeben oder vervielfältigt werden.

Tutti i diritti riservati. Nessuna parte di questo libro può essere riprodotta in nessun formato cartaceo o elettronico, senza la previa autorizzazione dell' editore o dei proprietari dei diritti.

Todos os direitos reservados. Nenhuma parte deste livro pode ser reproduzida em qualquer formato de papel ou electrónico, sem o consentimento prévio do editor ou dos proprietários dos direitos.



LEDS-C4, S.A.

Afueras s/n – 25750 Torà (Lleida) - SPAIN

www.leds-c4.com

España

Tel.: 973 468 101

Fax.: 973 468 129

e-mail: info@leds-c4.com

France

Tel.: + 34 973 468 130

Fax.: + 34 973 468 129

e-mail: france@leds-c4.com

Portugal

Tel.: + 34 973 468 130

Fax.: + 34 973 468 129

e-mail: portugal@leds-c4.com

Europe

Tel.: + 34 973 468 102

Fax.: + 34 973 468 106

e-mail: europe@leds-c4.com

América Latina

Tel.: + 34 973 468 115

Fax.: + 34 973 468 106

e-mail: sudamerica@leds-c4.com

USA - Canada

Tel.: +34 973 468 109

Fax: +34 973 468 106

e-mail: lighting@leds-c4.com

Asia - Pacific & Africa

Tel.: + 34 973 468 116

Fax.: + 34 973 468 106

e-mail: export@leds-c4.com

Middle East Countries

Tel.: + 34 973 468 108

Fax.: + 34 973 468 106

e-mail: dep-export@leds-c4.com

